



# User Manual

## K2B12VG31-1

### Rechargeable LiFePO4 Battery



# Technical Specs

<b>Electrical</b>	
Rated Capacity	100Ah
Nominal Voltage	12.8V
Voltage Range	10.0V-14.6V
Maximum Continuous Charging Current	50A
Maximum Continuous Discharging Current	100A
Maximum Pulse Discharge Current $\leq 5$ sec	150A
Series Connection Allowed:	2
Parallel Connection Allowed:	4
Cycle Life	>2000
Self-Heating	No

<b>Environment</b>	
Discharge Operation Temperature	-20°C to 60°C
Charge Operation Temperature	0°C to 60°C
Storage Temperature	0°C to 45°C

<b>Structure</b>	
Dimensions	327*172*220mm
Weight	11.2KG
Protection Features	Overcharge, Over Discharge, Overcurrent, Short Circuit, Too High/Low Temperature

<b>Certifications</b>	UN38.3, FCC, UL
<b>Warranty</b>	5 Years

# Dimensions

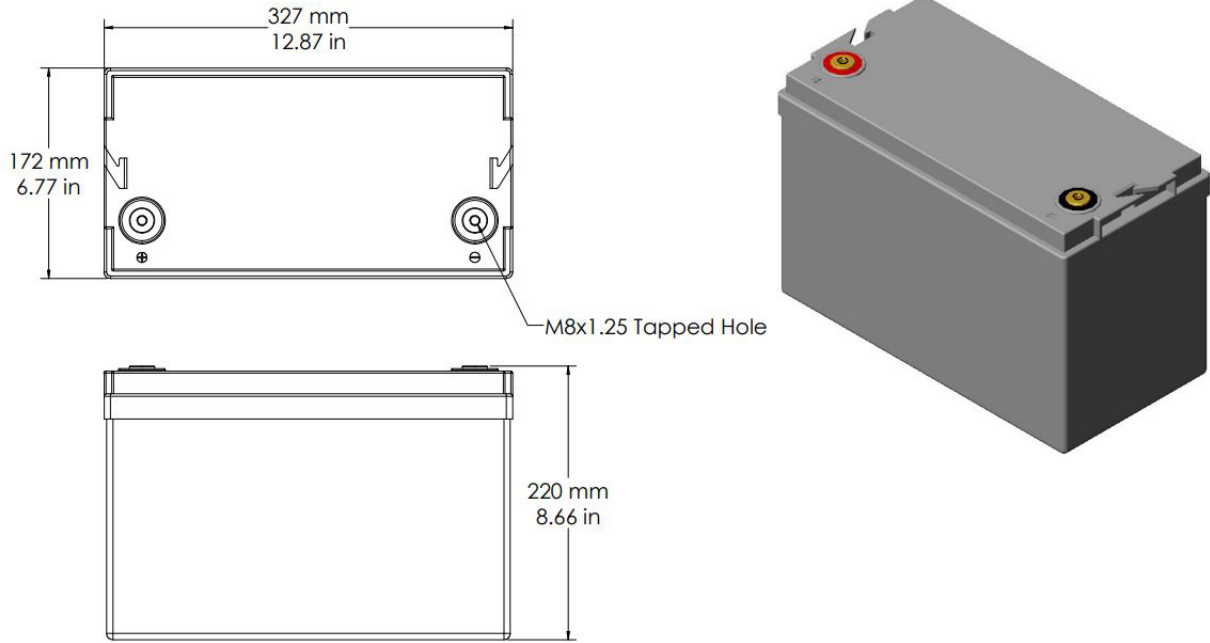

# Installation

Attach terminals of device to power terminals of the battery of the same polarity ( +/Red, -/Black) using screw and washer kit supplied with the battery as shown in below image.

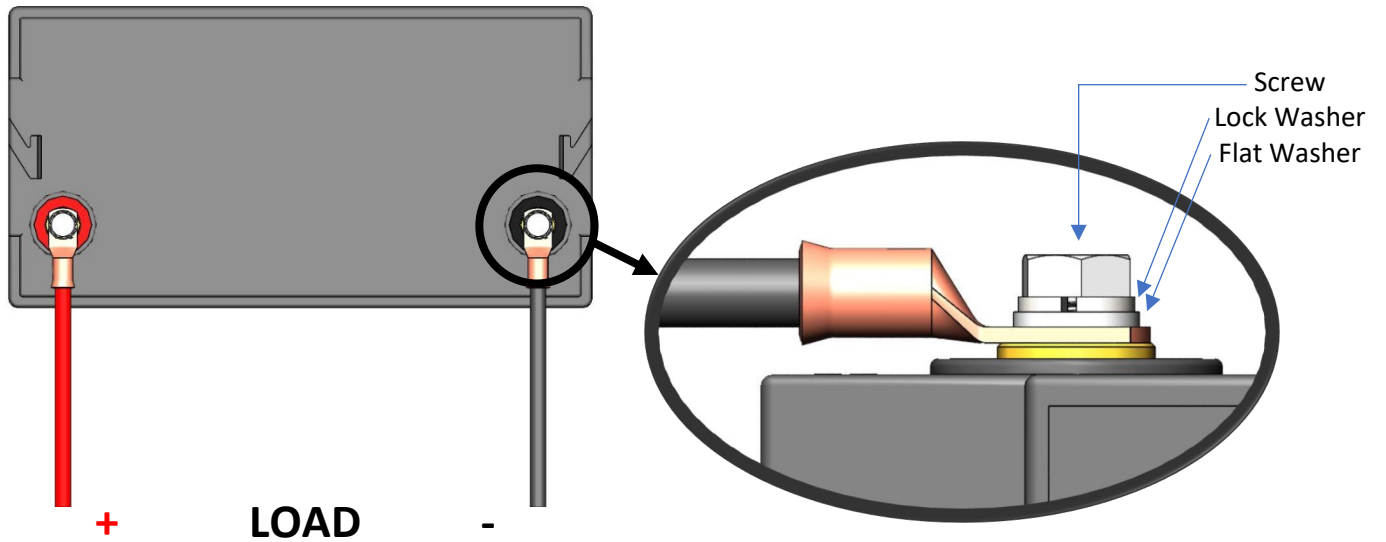

## WARNING

Reversing polarity could cause damage to load or battery

# Series and Parallel Connections

The K2B12VG31-1 battery is capable of being wired with up to 2 units in series for increased voltage (24V) and up to 4 units for increased capacity (400Ah). Wiring diagram shown below.

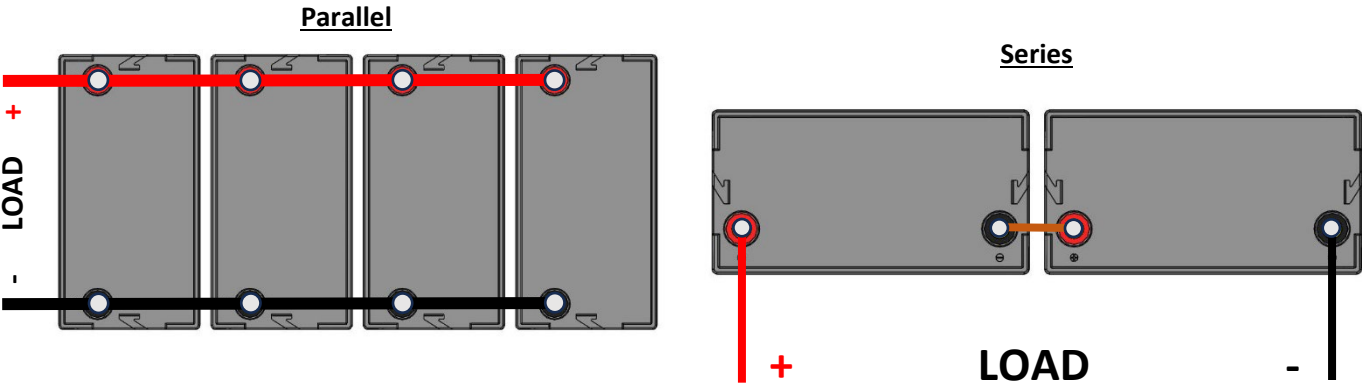

## 2S4P Connection

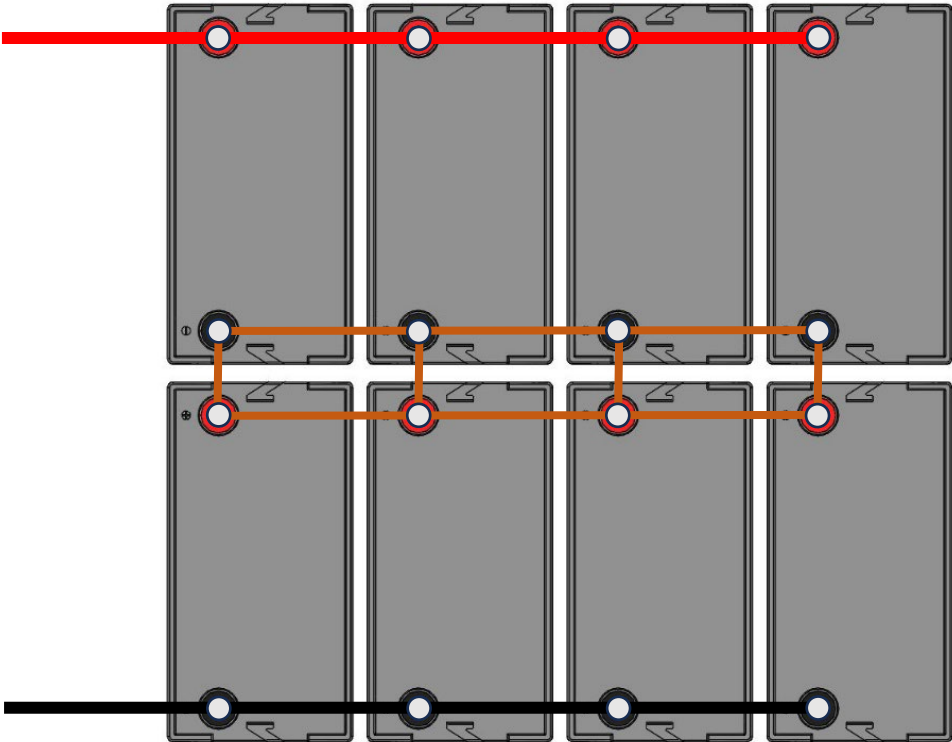

# Warranty

## Warranty for LFP Battery

This warranty applies to all LFP Batteries (the “Product”) manufactured and sold by K2 Energy Solutions. The Product is warranted against defects in material and workmanship under normal use and service for the following period from the date of purchase:

1. A warranty period of 60 months for the product, during which K2 Energy Solutions will cover 100% of the cost of any replacement or repair of a defective Product or component, within the first 24 months. After the first 24 months, K2 Energy Solutions will continue to offer a prorated warranty, during which K2 Energy Solutions will cover 50% of the cost of any replacement or repair of a defective Product or component. The prorated coverage will decrease by 1.38% per month, until it reaches 0% coverage at the end of the warranty period.

During the warranty period, K2 Energy Solutions will repair or replace, at its option, any defective Product or component free of charge or at the discounted rate as described above, provided that the Product is returned to K2 Energy Solutions or an authorized service center with proof of purchase.

This warranty does not cover any damage to the Product caused by:

1. Accident, abuse, misuse, neglect, or any other abnormal use;
2. Modification, alteration, repair or service performed by any party other than K2 Energy Solutions;
3. Improper installation or application;
4. Environmental conditions, including but not limited to extreme temperatures, condensing humidity, and corrosive atmosphere;
5. Normal wear and tear; or
6. Acts of nature, such as fire, flood, storms, or earthquake.

This warranty is the sole and exclusive warranty provided by K2 Energy Solutions regarding the Product and supersedes all other warranties, whether written or oral, express or implied, including but not limited to any warranty of merchantability or fitness for a particular purpose.

The remedies provided in this warranty are the sole and exclusive remedies available to the customer.

K2 Energy Solutions shall not be responsible for any indirect, incidental, or consequential damages arising from the use of the Product, including but not limited to lost profits or lost data.

To make a warranty claim, please contact K2 Energy Solutions at [info@k2battery.com](mailto:info@k2battery.com) or 702-478-3590.

This warranty gives you specific legal rights, and you may also have other rights which vary from state to state.

## Optional Extended Warranty for LFP Battery

In addition to the standard warranty described above, K2 Energy Solutions also offers an optional extended warranty for the Product for an additional cost of 10% of the purchase price, per year. The extended warranty will extend the 100% coverage of the original warranty’s 24 months, providing customers with continued peace of mind for their Product. This extended warranty may only be purchased at the time of initial sale and is not available for purchase after.

Under the extended warranty, K2 Energy Solutions will continue to repair or replace, at its option, any defective Product or component free of charge for the duration of the extended warranty period. The extended warranty is subject to all the same limitations and exclusions as the standard warranty described above.

Customers interested in purchasing the optional extended warranty should contact K2 Energy Solutions at [Info@k2battery.com](mailto:Info@k2battery.com) or 702-478-3590 for more information and to make arrangements to purchase the extended warranty.